

Ergonomics -

Precise positioning of
healthcare equipment

Proven supplier of healthcare solutions

Southco healthcare access hardware solutions combine physical product strength with ease of installation and user-friendly operation. These products and systems provide greater flexibility, reliability and lower overall cost of ownership than hardware available from other manufacturers. As a system specialist, we offer a complete range of products that meet the healthcare industry standards for security, safety, precision and hygiene.



■ POSITION IT

■ CONCEAL IT

■ MOUNT IT

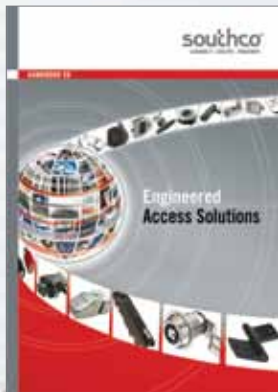

Order your **FREE Southco Handbook** on info@southco.com and gain access to the industry's most comprehensive resource for access hardware solutions.



■ CONTROL IT

■ ACCESS IT

■ FASTEN IT

■ SECURE IT

■ OPEN IT

Please visit www.southco.com to view our complete range of solutions

Southco Positioning Technology

- the healthcare industry's choice for user-friendly motion

The positioning ease of monitors and medical devices is essential to optimal user comfort and patient care. As a long-time partner of top global healthcare equipment manufacturers, Southco leads the way in positioning technology within the healthcare sector.

- Ensuring user interfaces are within easy reach
- Allowing precisely positioned lighting
- Enabling equipment to be firmly held and easily repositioned, without mechanical lock
- Permitting heavy covers and lids to be lifted with minimal effort
- Providing reliability without maintenance or adjustment

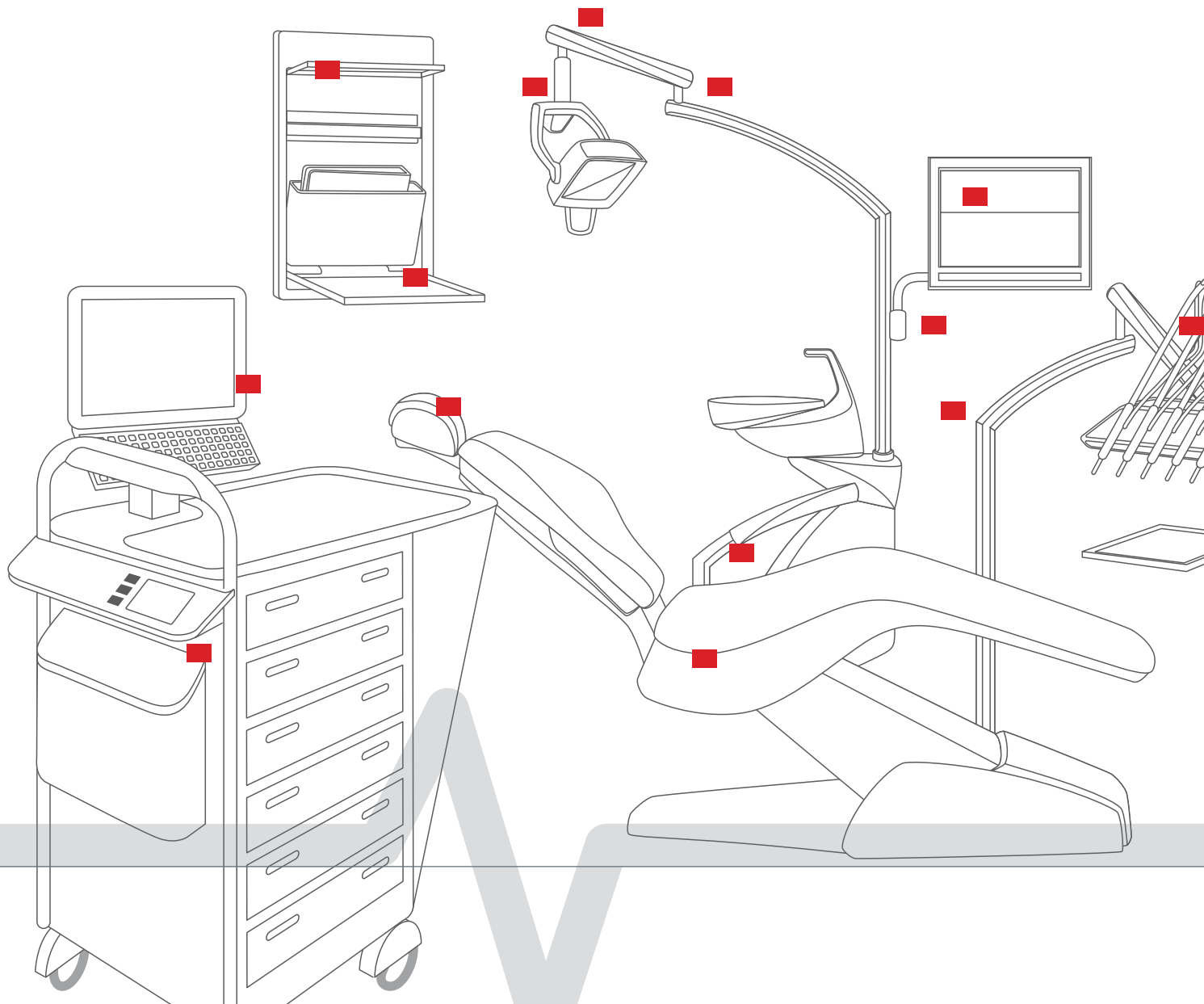

Position Control Hinges and Mounting Arms

- *controlled movement and positioning of equipment*

Southco's engineering expertise in positioning technology enhances functionality, precision and user experience of healthcare equipment. From the most basic friction hinges, to highly sophisticated position control devices, Southco's reliable solutions ensure long-lasting performance throughout the life of your product.

- Constant torque hinges for smooth and secure positioning of keyboards, screens, headrests and lighting
- Counterbalance mechanisms to lift heavy equipment effortlessly
- Bi-stable hinges for the controlled motion of flip lids on portable devices
- Tilt and swivel mechanisms for easy screen adjustment and shared screen views
- Arms for easy 'no drift' positioning of monitors

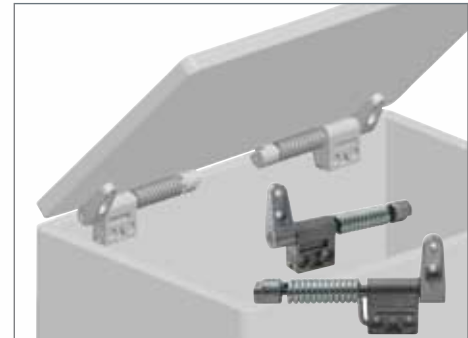
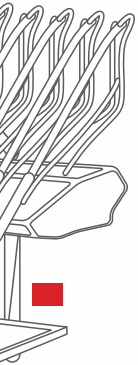
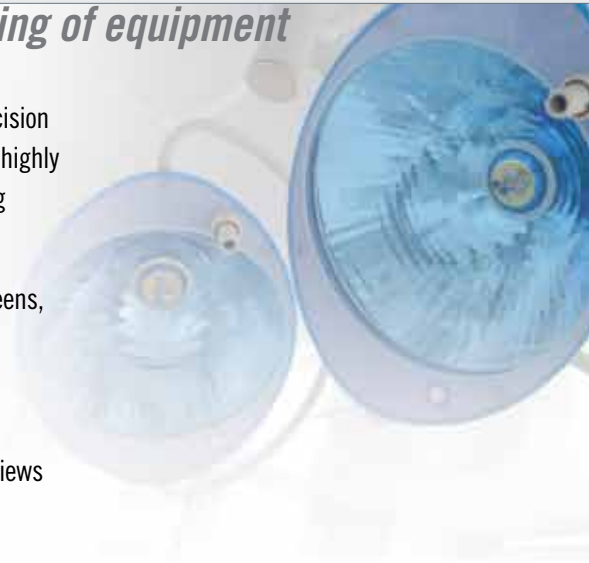

Please visit www.southco.com to view our complete range of solutions

Custom Designed Solutions - unparalleled flexibility

Southco's custom engineered position control solutions will give your medical equipment the competitive edge. From integrating a hinge into existing requirements to custom tailoring a complete solution, our global engineering team can satisfy the industrial design, operating effort, degree of motion and vibration resistance requirements with ease.

- Position hinges for portable computer displays to fit specific packaging and strength requirements
- Monitor arms that can be removed from the equipment and mounted elsewhere
- Position devices that permit screens to fold flat for transport yet hold securely against touch screen forces while in use
- Multi-axis monitor arms that allow for unlimited positioning options



Safety & Security -

Intelligent access control
for healthcare equipment

Proven supplier of healthcare solutions

Southco healthcare access hardware solutions combine physical product strength with ease of installation and user-friendly operation. These products and systems provide greater security, reliability and lower overall cost of ownership than hardware available from other manufacturers. As a system specialist, we offer a complete range of products that meet the healthcare industry standards for security, safety, precision and hygiene.

Electronic and mechanical access solutions



■ CONTROL IT

■ LOCK IT

■ SECURE IT

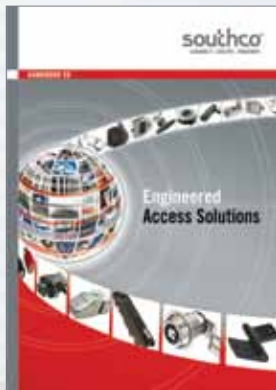

Order your **FREE Southco Handbook** on info@southco.com and gain access to the industry's most comprehensive resource for access hardware solutions.



■ POSITION IT

■ ACCESS IT

■ FASTEN IT

■ SECURE IT

■ OPEN IT

Please visit www.southco.com to view our complete range of solutions

Southco's Access Hardware Solutions

The healthcare industry's choice for security and safety

Southco's access systems – from simple mechanical latching to sophisticated electronic access – are designed to meet the healthcare industry's strict measures for increased security and patient safety driven by industry regulations such as HIPAA and EU directives on data protection.

- Simplified controlled access for authorised users
- Restricted access to patient records, medications and equipment
- Secure storage of controlled substances and supplies
- Remote monitoring and audit trail control for regulatory compliance

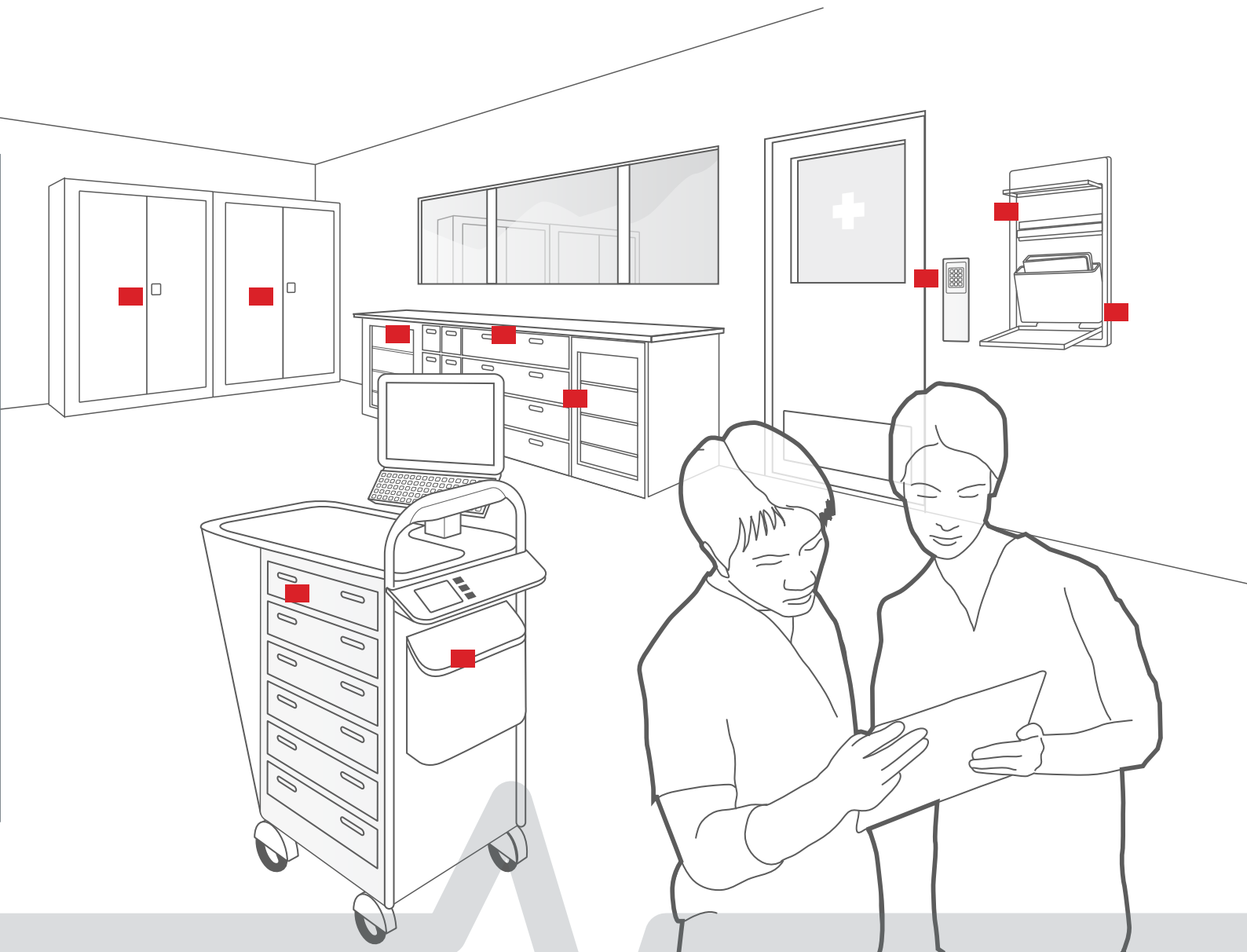



Mechanical Access Solutions

Security at its simplest

Southco offers a wide range of mechanical locking and latching solutions to restrict access to medical equipment and records in hospitals and doctor's offices. From basic quarter-turn locks to advanced compression and push-to-close latches, our solutions protect information, medications and supplies.

- Robust and vandal-resistant locks
- Flexible Key Choice systems with “keyed alike” or “keyed differently” locking options
- Push-to-close latches that automatically lock when door is shut
- Compression latches and multipoint systems for security at multiple pry points
- Stainless steel products for durability and corrosion resistance



Please visit www.southco.com to view our complete range of solutions

The proven global leader in engineered access solutions

The advantage of 60 years of engineered access hardware and fastener experience lies in our cumulative applications knowledge and engineering expertise that make our broad range of existing solutions possible. In addition, our global manufacturing resources benefit OEMs and CEMs worldwide - no matter where they design, assemble, or sell. Southco offers flexibility and fast response:

- **Engineering assistance on your schedule.** Southco engineering resources in three key regions - North America, Europe, and Asia-Pacific - provide easy access to more than 150 design and sales engineers globally.
- **Quick turnaround, on your timetable.** 14 strategically located Southco manufacturing, assembly, and stocking facilities - in 8 countries across 4 continents - shorten lead times, lower shipping costs, and improve scheduling.
- **Extensive capabilities for your benefit.** In-house resources - stamping, die-casting, cold-heading, roll-forming, turning, injection-molding, and assembly - at Southco Centres of Excellence around the world transform raw stock into polished solutions.
- **Personal assistance, as you need it.** The 24/7 availability of experienced Southco personnel - regardless of geographic location - delivers the timely attention you require.

Whatever your access hardware needs, no one offers more. Contact a Southco representative today, to discover all the possibilities.



Global Corporate Headquarters & Customer and Technical Support Centre
Concordville, PA · USA
 Tel: (1) 610 459 4000
 Fax: (1) 610 459 4012

Canada Tel: (1) 905 855 0309
Mexico Tel: (1) 877 821 0666

Manufacturing & Stocking Locations
 Chihuahua, Mexico
 Concordville, Pennsylvania
 Honeoye Falls, New York
 Tecate, Mexico
 Rockledge, Florida

Europe Customer & Technical Support Centre
Worcester · UK
 Tel: (44) (0) 1905 346722
 Fax: (44) (0) 1905 346723

Austria Tel: 0800 281 831
France Tel: 0800 912 756
Germany Tel: 0800 1800 380
Italy Tel: 800 780 953
Spain Tel: 900 968917
Sweden Tel: 020 790 366
UK & NI Tel: 0845 117 9222

Manufacturing & Stocking Locations
 Farnham, UK
 Worcester, UK

Asia Customer & Technical Support Centre
Hong Kong · China
 Tel: (852) 3127 1503
 Fax: (852) 3127 1541

China Tel: 800 820 0272
Japan Tel: 00531 121672
Korea Tel: 0505 777 1234
Malaysia Tel: 1800 801 119
Singapore Tel: 800 18 11016
Taiwan Tel: 0800 558 015

Australia Customer Service and Distribution Centre
Tullamarine · Victoria 3043 · Australia
 Tel: (61) 03 9330-5000 · Fax: (61) 03 9330 - 5099

India Customer Service and Technical Support Centre
Taluka Shirur · Pune 412208 · India
 Tel: (91) (21) 3867 0538 · Fax: (91) (21) 3867 0588

Manufacturing & Stocking Locations
 Hong Kong, China Shanghai, China
 Melbourne, Australia Shenzhen, China
 Pune, India Tokyo, Japan
 Seoul, South Korea